

MODIFICHE: 01. Inserir codice 8U34300029, 8U35300005 e 8U35300014. (25/11/2019 Davide Pisotti)
 Varianti: 02. INSERITI CODICI SSA00107249, SSA00107249, SSA00107248, 8U44700023. CODICI 8U43010012, Q.TA DA 2 A 3. 8U35300014, 8U35300029, 8U34300014, Q.TA DA 4 A 6. 8U35300007, Q.TA DA 6 A 10. RIMOSSO CODICE 8U70430035. (12/12/2019 Nicola Trombini)

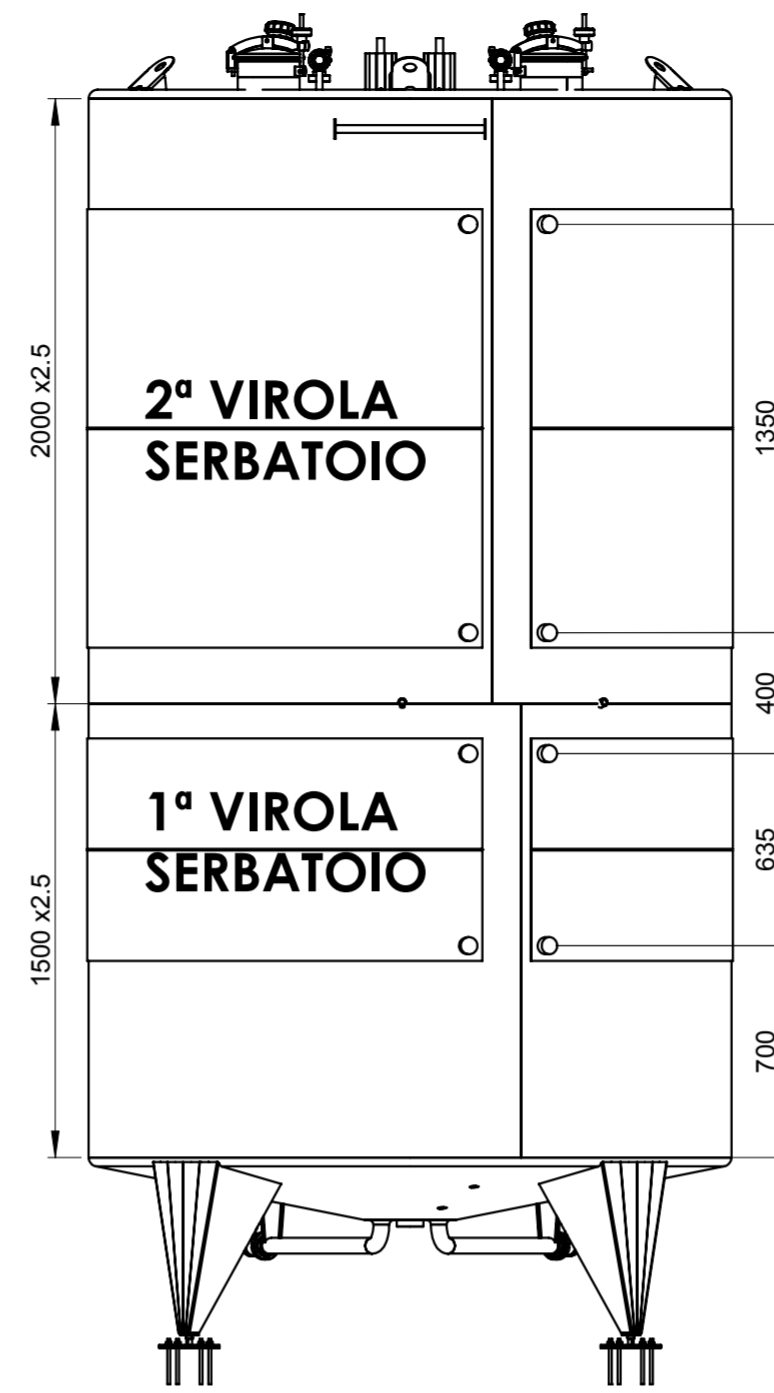

D-D
SCALA (1 : 20)

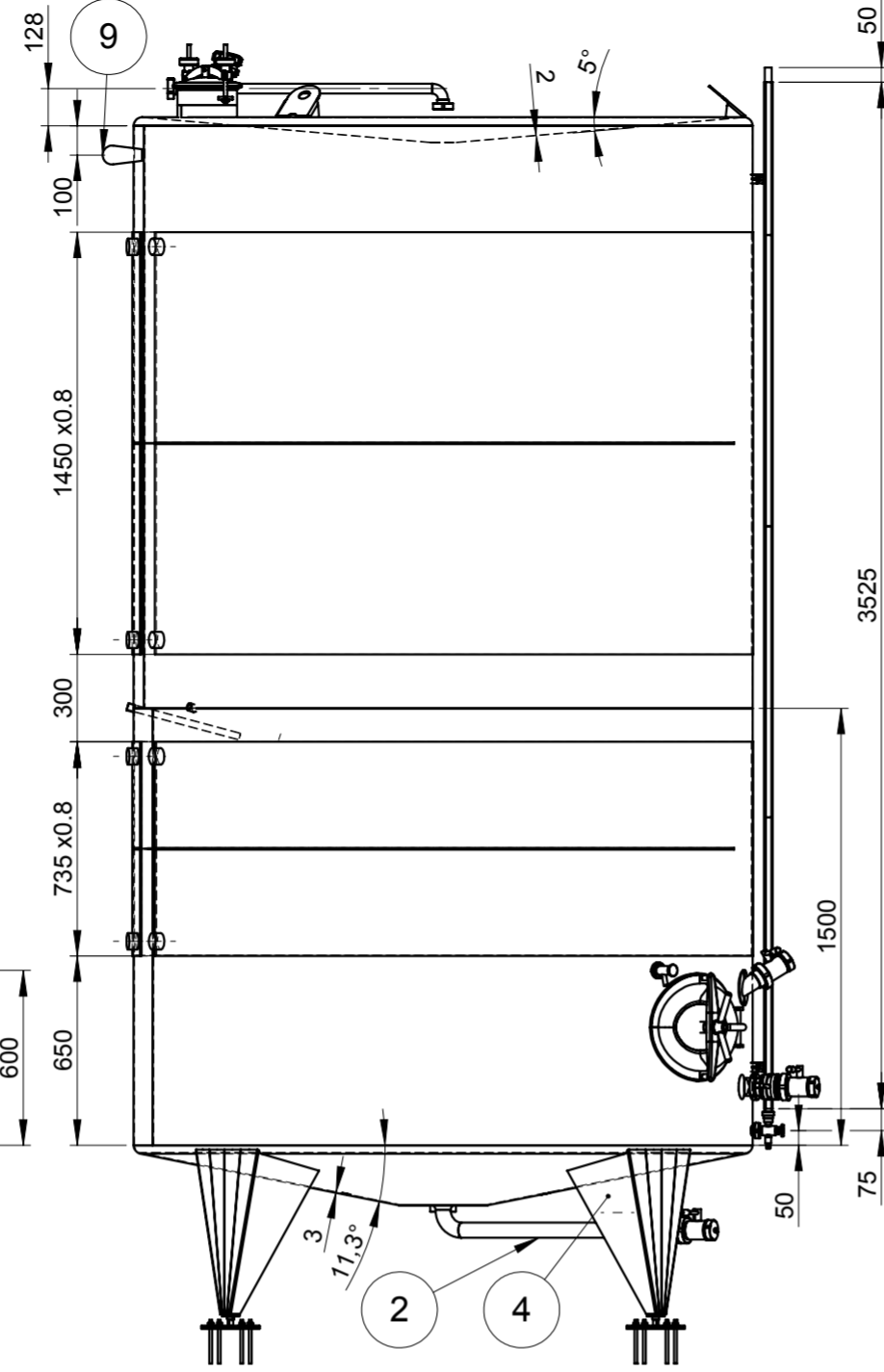
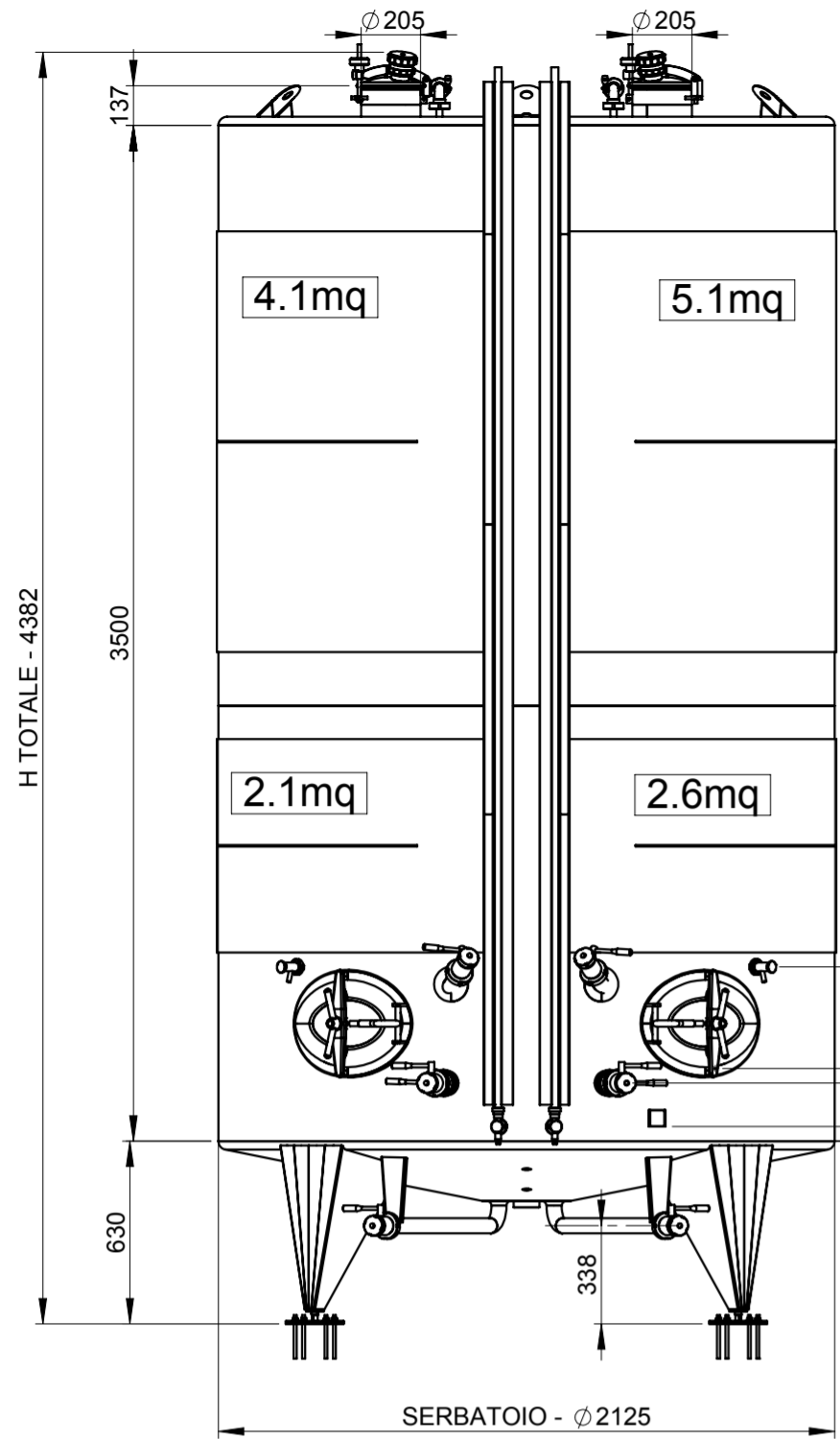
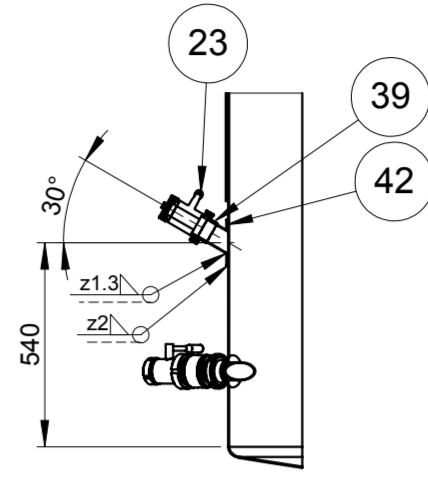

E
SCALA (1 : 10)

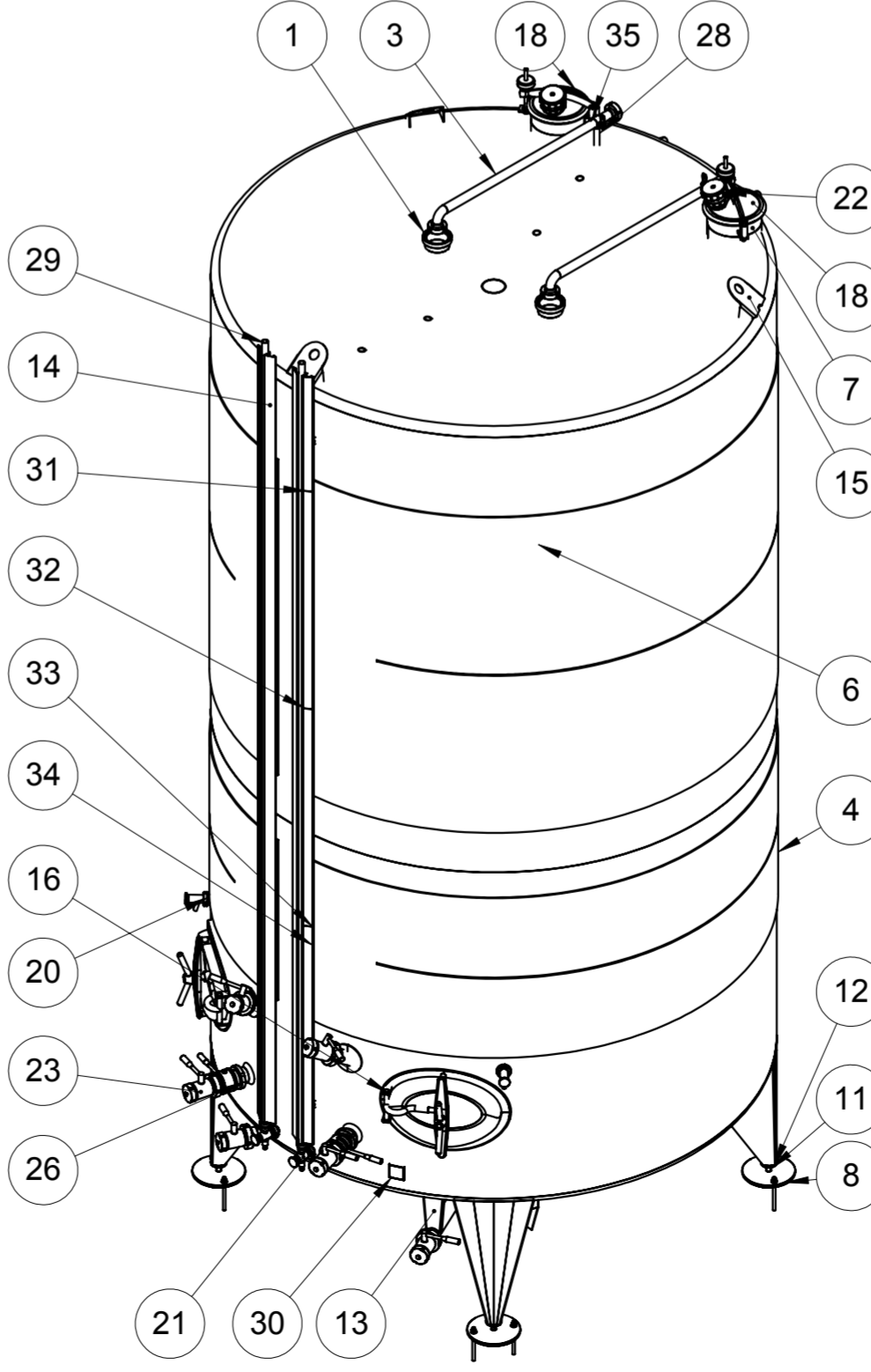
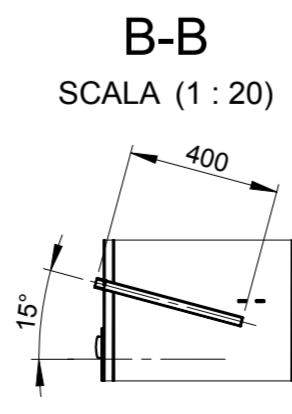
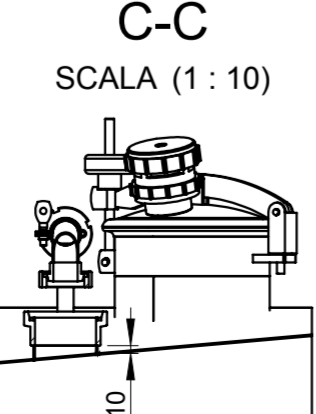
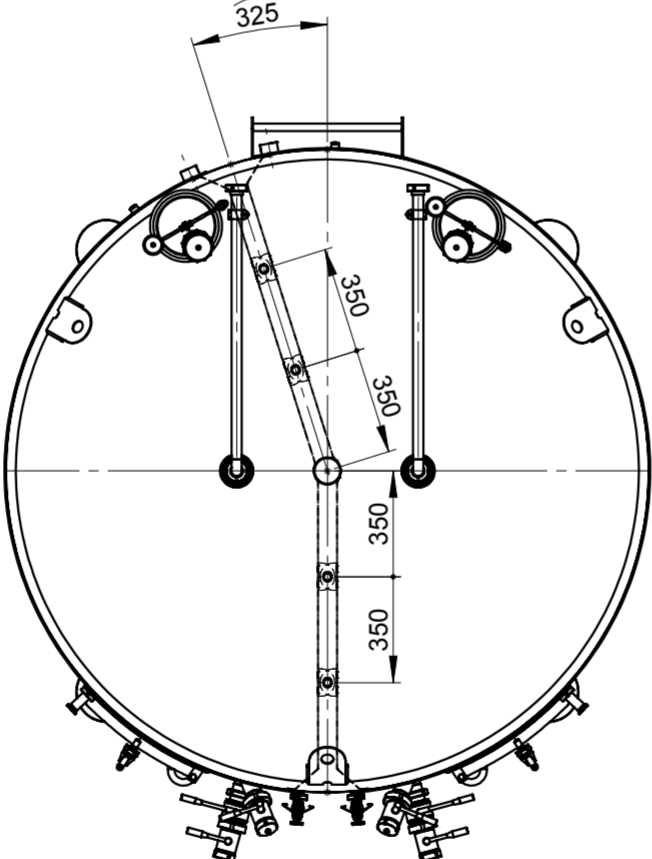
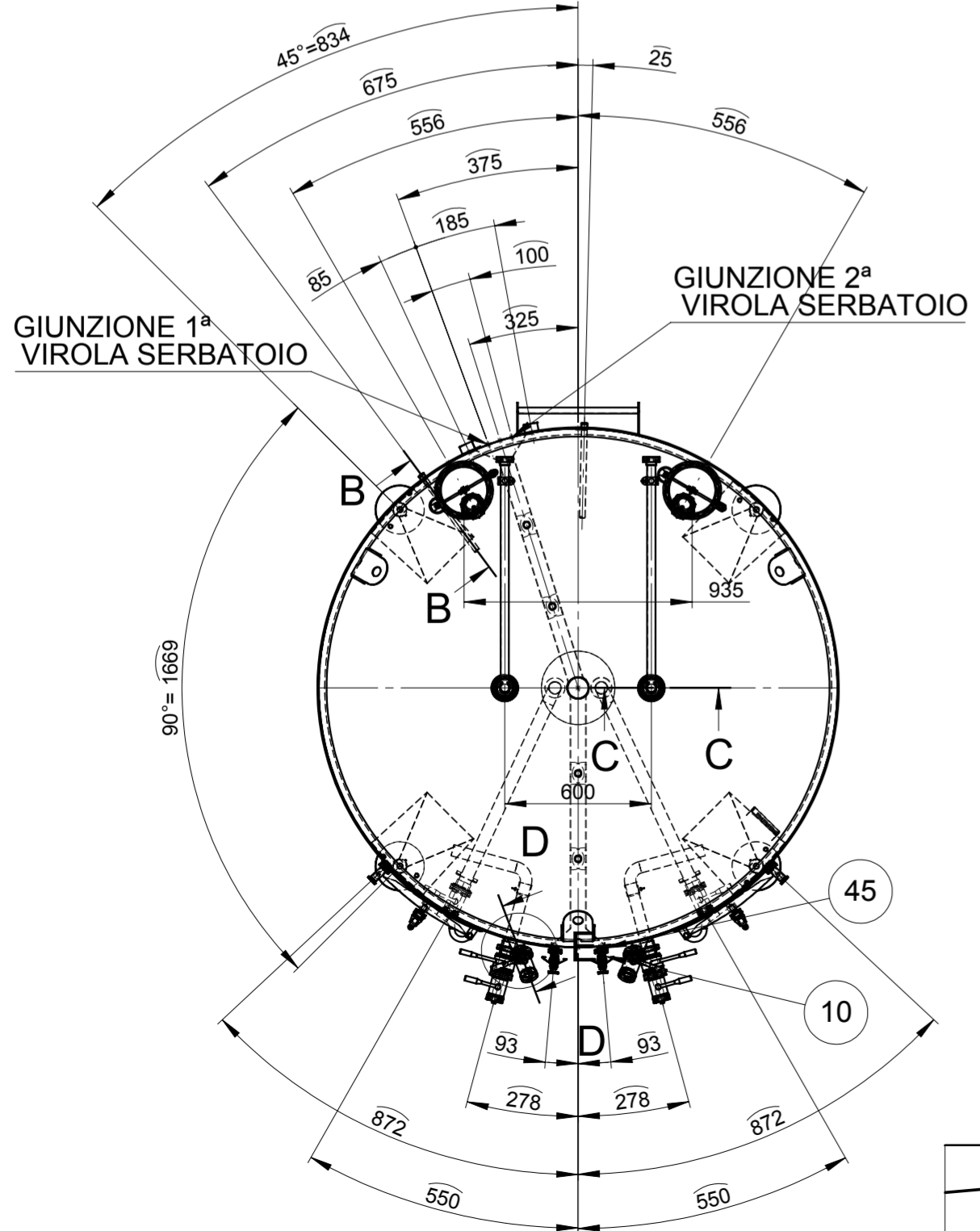
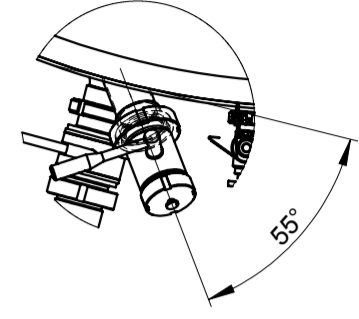

②	45	SSA00100117	4	STAFFA FISS. GUAINA 43X 30X 3,0 A304
②	44	SSA00107249	1	ROSETTA A DIS. Ø 120 SP 4 MM SAT GR220
②	43	8U44700023	2	VALV.DECANTAZ. DN 50 304 DIN MG/F. RS
②	42	SSA00107249	1	ROSETTA A DIS. Ø 120 SP 4 MM SAT GR220
②	41	8U43010012	3	VALV.SF/2V. A304 DN 50 DIN MG/F-32 RZ
②	40	SSA00107248	1	TUBO DN 50 RF DIN 11851 L=135
②	39	SSA00107248	1	TUBO DN 50 RF DIN 11851 L=135
②	38	8U35300014	6	GUARN.GOMMA PIANA-GIR/CIECA DN 32 DE 58
②	37	8U35300005	6	GUARN.GOMMA ALIM/TONDA DN 32 DIN 11851
②	36	8U34300029	6	GIRELLA CIECA/CATEN.DN 32 DIN11851 A304
②	35	8U31300014	2	REGGITUBO CON CERNIERA 1/2" DE 33,7
②	34	8U33050244	2	ETIC.AD. 35X1000 MM (000-099) MILLIM.
②	33	8U33050245	2	ETIC.AD. 35X1000 MM (100-199) MILLIM.
②	32	8U33050246	2	ETIC.AD. 35X1000 MM (200-299) MILLIM.
②	31	8U33050247	2	ETIC.AD. 35X1000 MM (300-399) MILLIM.
②	30	8U33050264	1	TARGA LOGO DEFRANCESCHI DESIGN
②	29	8U33801008	2	TUBO PLEXI DE 24/20 L= 3750
②	28	8U34100013	2	TRONCHETTO A SALD. 1/2" L130 A304
②	27	8U34330003	4	RACC.FEMM/SALD.GROSSA 304 DN 20 DIN11851
②	26	8U34330007	2	RACC.FEMM/SALD.GROSSA 304 DN 50 DIN11851
②	25	8U35300003	4	GUARN.GOMMA ALIM/TONDA DN 20 DIN 11851
②	24	8U35300007	10	GUARN.GOMMA ALIM/TONDA DN 50 DIN 11851
②	23	8U43010012	3	VALV.SF/2V. A304 DN 50 DIN MG/F-32 RZ
②	22	8U43170001	2	VALVOLA DOPPIO SFIATO DN 50 LAVEGGI
②	21	8U44440005	2	PORTALIVELLO INF. DE24 DN10 MG/20 A304
②	20	8U44460040	2	ASSAGG. VALVO DN20 MG/20
②	19	8U44600031	2	VOL. INOX 2 RAZZE M18 LU ART.A3/B5
②	18	8U44600969	2	COPERCHIO CHIUS.RF/50 A316 DN200 "D 8R"
②	17	8U44600958	2	COP.PORT.OVALE A304 440X310 "A3" R/32
②	16	8U44600959	2	TELAIO P/OVALE A304 10X30 "A3" R/32
②	15	8U70430085	3	STAFFA SOLL. PIEG. 136X160X 4 F/40 A304
②	14	8U70500121	2	ASTA GUAINA SEGN.28X26 L=3650 T.N. A304
②	13	8U70520037	2	SUPPORTO REGGIT. DN50 H=270 A304/2B
②	12	8U71020077	4	BOCCOLA PER VITE M24 D60/54 H=30 A304
②	11	8U71110013	4	VITE REGOLAZIONE PIEDE M24 UNI 4535-64
②	10	8U71160022	4	SUPPORTO REGGIGUAINA 25X32X30 A304
②	9	8U71200186	1	APPOGGIO SCALA 500X135 (MOD.FR) A304
②	8	SSA00103046	4	PIATTELLO PER VITE M24
②	7	SSA00106036	2	TELAIO CHIUSURA DN200 HC=230 A316 LU/SAT
②	6	SSA00115901	2	POZZETTO PER SONDA 1/2" F. L=400 A304
②	5	SSA00155003	1	TARGA SERBATOIO NO CE 148X105 A SILDARE
②	4	SSF00102900	1	GRUPPO LAMIERE Ø2125-HF3500
②	3	SSF00107002	2	TUBO DI LAVAGGIO DN32 L=1025 A304 LU/2B
②	2	SSF00107003	2	CURVA -TUBO-RF DIN DN50 L=878 H=70 A304
②	1	SSF00107004	2	TUBO RF DIN DN80 L=85 A316
②	POS.	CODICE / Code	Qt.	DIMENSIONI GREZZE - DENOMINAZIONE - NOTE Approx. dimension - Descriptions - Notes
				PEZZO SBAVATO CON CURA Properly trimmed piece
				QUOTE SENZA INDICAZIONE DI TOLLERANZA / Measures unspecified tolerances SP-PG016 mK
				MASSA / Mass 1579kg
				CLASSIF. PROD. / Product classificat. B
				SPICOLI/NON QUOTATI / Unquoted edges

defranceschi SERBATOIO DOPPIA CELLA D2125 F03500
 a company of **SACMI**
 Via Broletto, 10/A - I-40026 Imola (BO)

Dis. / Draft man: **Davide Pisotti**
 DATA / Date: **15/10/2019**

F.TG. / Size: **A2**
 SCALA / Scale: **1:25**

FOGLIO / Sheet: **1/2**
 SCALA / Scale: **1:25**

CODICE MATERIALE / Material code: **SSF001A-0004**
 REV. / Rev.: **02**

Proprietà riservata - Riproduzione vietata - La Ditta tutela i propri diritti sui disegni a termine di legge.
 All rights reserved - Drawings cannot be reproduced in any way, failure to do so will entitle Sacmi to take legal action.

ULTIMO SALVATAGGIO / Last saved: 12/12/2019 12:24:58
 4700448516/02AA

SOSTITUISCE IL, in place of: _____
 SOSTITUITO DA / Replaced by: _____

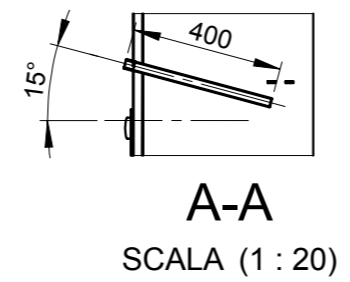
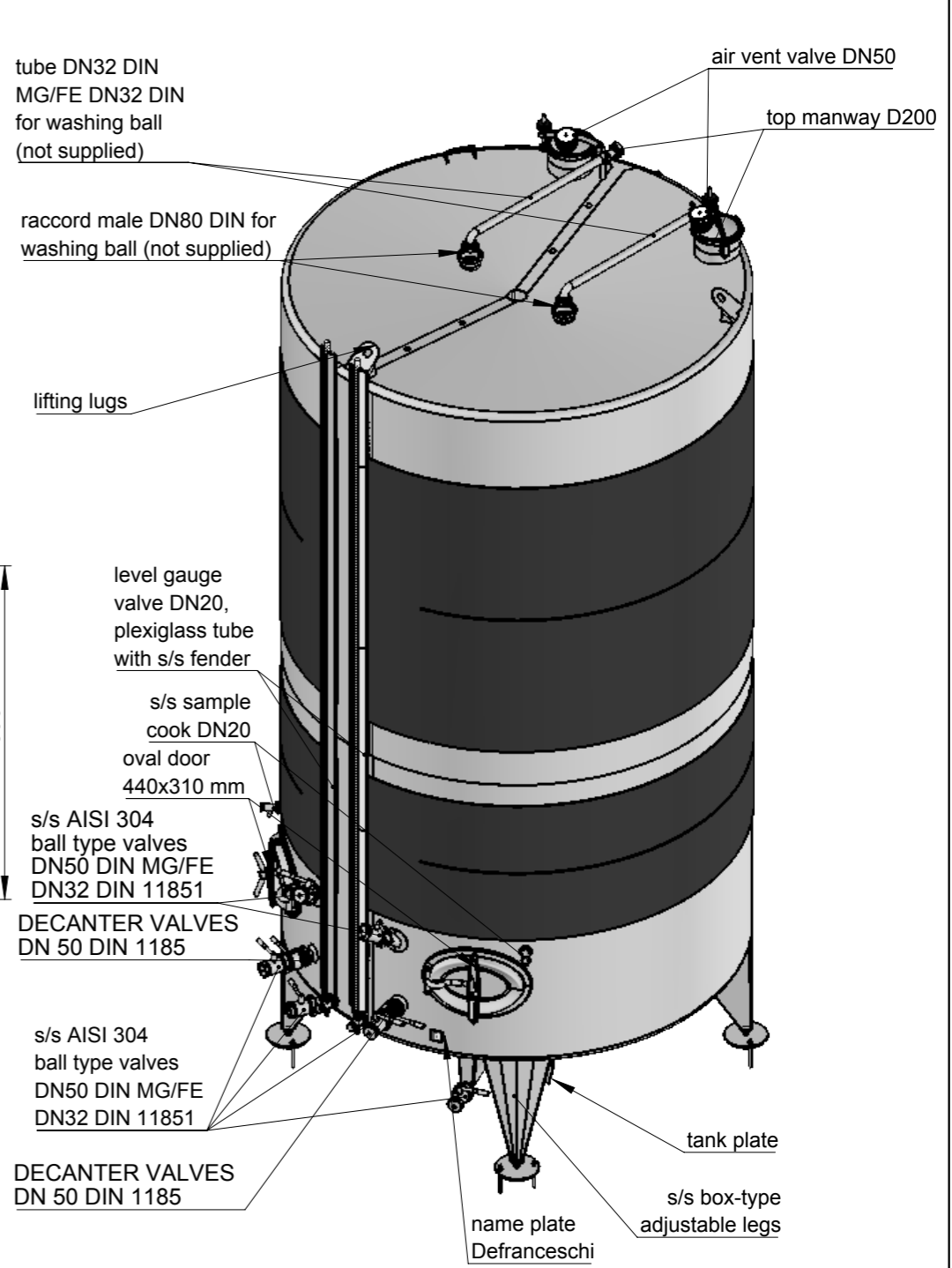
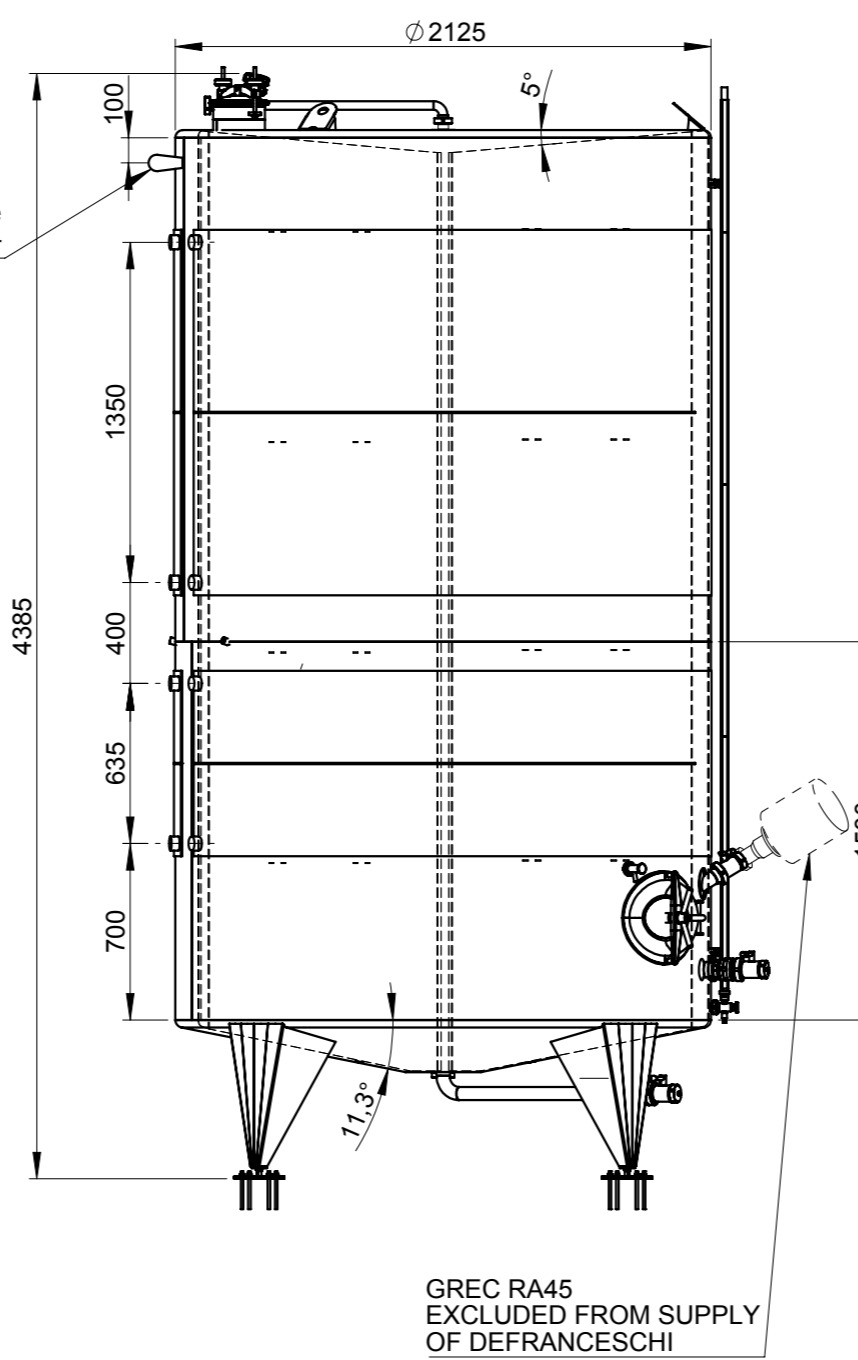
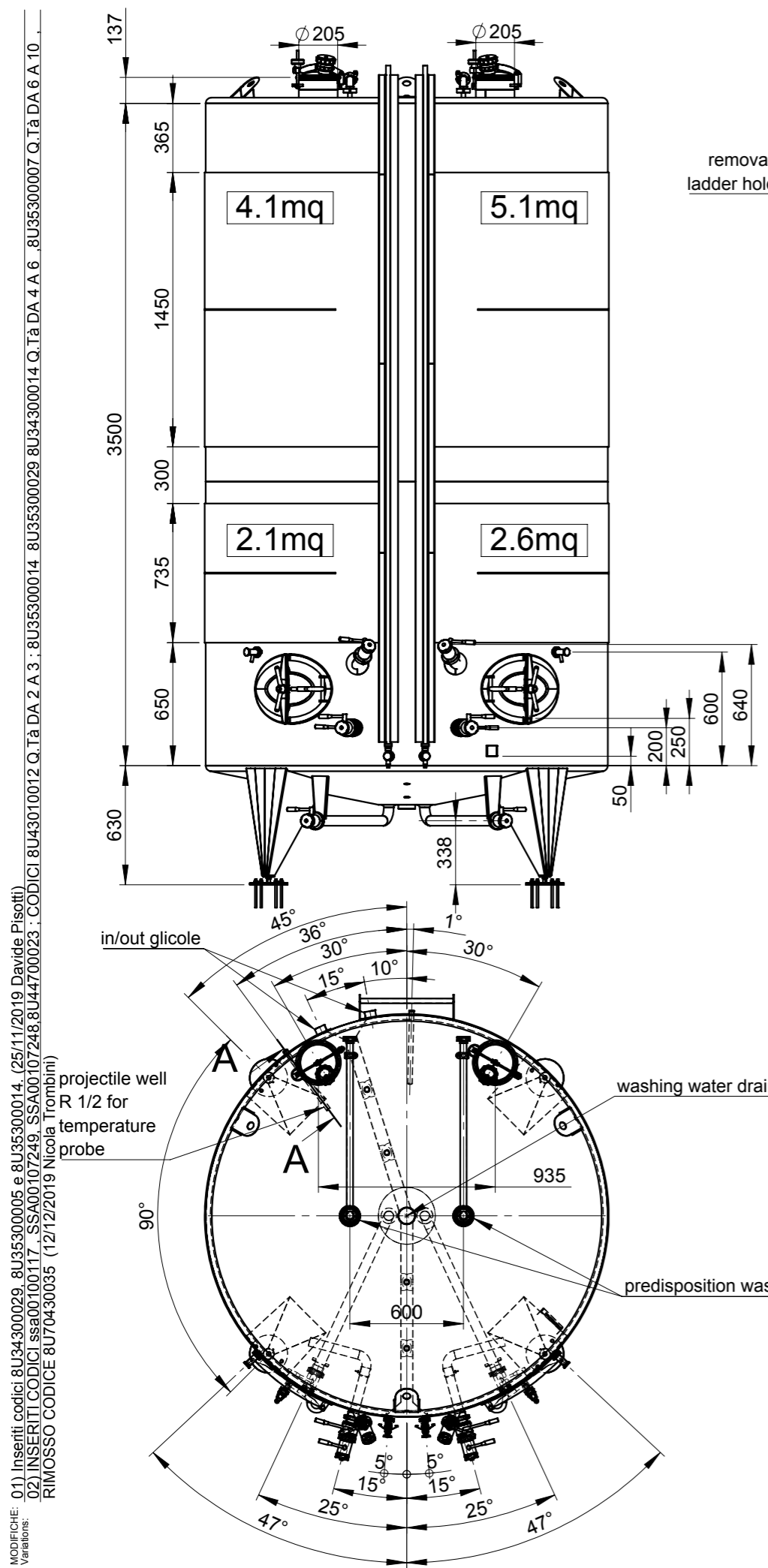

Nominal capacity: 5.000+6.000 litres

Material (with guarantee certificate):
floating lid s/s AISI 316, remaining parts s/s AISI 304

Surface finishing:
internal surfaces: industrial mirror polished;
cleaned and brushed welding seams
external surfaces: cyl. sheet SATINED GR220, bottom and cap 2B;
cleaned, brushed and strip satin finished welding seams

Heat exchange:
Inox AISI 304/SATINED GR220 PIGMENTED

MODIFICHE: 01. Inseririti codici 8U34300029, 8U35300005 e 8U35300014. (25/11/2019 Davide Pisotti)
 Variations: 02. INSERITI CODICI SSA00100117, SSA00107249, SSA00107248, 8U44700023. CODICI 8U43010012 Q.Tà DA 2 A 3. 8U35300014. 8U35300029 8U34300014 Q.Tà DA 4 A 6. 8U35300007 Q.Tà DA 6 A 10. RIMOSSO CODICE 8U70430035 (12/12/2019 Nicola Trombini)

PEZZO SBAVATO CON CURA Properly trimmed piece	QUOTE SENZA INDICAZIONE DI TOLLERANZA/ Measures unspecified tolerances	MASSA / Mass SP-PG016 mK 1579kg	CLASSIF. PROD./ Product classificat. B	SPIGOLI NON QUOTATI/ Unquoted edges
defranceschi SERBATOIO DOPPIA CELLA D2125 F03500				
a company of SACMI	DIS. / Draft man Davide Pisotti	F.TO/ Size A3	FOGLIO/Sheet 2/2	CODICE MATERIALE / Material code
Via Brodolini, 10/A - I-40026 Imola (BO)	DATA / Date 15/10/2019	SCALA/ Scale 1:30		SSF001A-0004
Proprietà riservata - Riproduzione vietata - La Ditta tutela i propri diritti sui disegni a termine di legge. All rights reserved - Drawings cannot be reproduced in any way; failure to do so will entitle Sacmi to take legal action.		ULTIMO SALVATAGGIO / Last saved 12/12/2019 12:24:58 4T00449516/02AA		SOSTITUISCE IL /in place of
				SOSTITUITO DA / Replaced by
				02